

NOTE

Thank you for purchasing the SPIRIT F7500 treadmill.

Please read carefully through all the precautions and instructions in this manual before using this equipment and keep this manual for your future reference.



F7500 TREADMILL

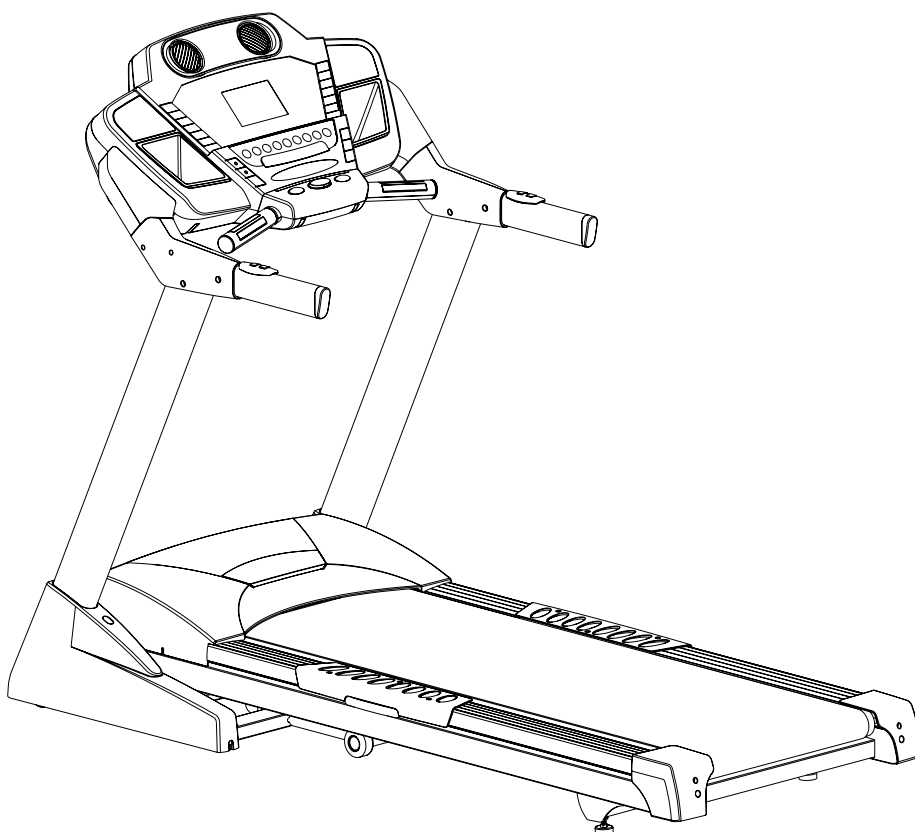

**SERVICE CENTRE
NUMBER**

For immediate help with assembly or for additional product information, please call our service center.

(DBN)

031 702 5784

(JHB)

011 907 1660

(CT)

021 934 0862

(PE)

041 487 0573

please have your model name ready when you call us.

**MAXIMUM USER
WEIGHT**

130kg

INSTRUCTION AND USER'S MANUAL

10155

CONTENTS

SAFETY PRECAUTIONS	page 1-2
PRE-ASSEMBLY CHECK LIST	page 3
PARTS LIST	page 4-6
HARDWARE PARTS LIST	page 7
EXPLODED DIAGRAM	page 8-12
ASSEMBLY INSTRUCTION	page 9-11
COMPUTER OPERATION INSTRUCTIONS	page 13-17
UNFOLDING/FOLDING AND TRANSPORT	page 18
BELT TRACKING ADJUSTMENT	page 19
TREADMILL LUBRICATION	page 20
EXERCISE INSTRUCTIONS	page 21-22
WARRANTY INFORMATION	page 23-25

SAFETY PRECAUTIONS

IMPORTANT: THIS UNIT IS INTENDED FOR HOUSEHOLD USE ONLY

Your treadmill was designed and built for optimum safety. However, certain precautions apply whenever you use your treadmill. Be sure to read the manual before assembly and operation.

Also, please note the following safety precautions:

DANGER: To reduce the risk of electric shock, always unplug the treadmill from the electrical outlet immediately after using and before cleaning.

1. Read OWNER OPERATING MANUAL and all accompanying literature and follow it carefully before using your treadmill.
2. If dizziness, nausea, chest pains, or any other abnormal symptoms are experienced while using this equipment, STOP the workout at once. CONSULT A PHYSICIAN IMMEDIATELY.
3. Never leave the treadmill unattended when plugged in. Unplug from the outlet when not in use and before removing or replacing parts.
4. Never operate the treadmill if it has a damaged cord or plug, if it is not working properly, if it has been dropped, damaged, or exposed to water.
5. Do not pull the treadmill by the power supply cord or use cord as a handle. Keep cord away from heated surfaces and open flames.
6. Fitness equipment must always be installed and used on a flat surface. Do not use outdoors or near water.
7. Do not insert any objects into any openings.
8. Keep children and pets away from this equipment at all times whilst exercising.
9. Handicapped individuals should have medical approval and close supervision when using this treadmill.
10. Do not place hands or feet under the treadmill. Always keep hands and legs off of the treadmill when others are using it.
11. Never turn on treadmill while standing on treadbelt. Always return the treadmill to slow speed to ensure a safe dismount and low speed restart.
 - a. To disconnect, turn all controls to the off position, then remove plug from outlet.
 - b. Use the treadmill only for its intended use as described in this manual.
 - c. Warm up 5 to 10 minutes before each workout and cool down 5 to 10 minutes afterward. This allows your heart rate to gradually increase and decrease and will help prevent straining muscles.
 - d. Never hold your breath while exercising. Breathing should remain at a normal rate in conjunction with the level of exercise being performed.
 - e. Start your program slowly and very gradually increase your speed and distance.
 - f. Always wear suitable clothing and footwear while exercising. Do not wear loose fitting clothing that could become entangled with the moving parts of your treadmill.
 - g. Do not walk or jog barefoot, in stocking feet or loose fitting shoes or slippers.

SAFETY PRECAUTIONS

h. Care must be taken when lifting or moving the equipment, so as not to injure your back.

Always use proper lifting techniques.

12. If the supply cord is damaged, it must be replaced by the manufacturer, its service agent or similarly qualified persons in order to avoid a hazard.
13. The treadmill is not to be used by children or persons with reduced physical, sensory or mental capabilities, or lack of experience and knowledge, unless they have been given supervision or instruction
14. Children being supervised should not to play with the treadmill.

WARNING

Before beginning any exercise program consult your physician. This is especially important for individuals over the age of 35 or persons with pre-existing health problems. Read all instructions before using any fitness equipment. We assume no responsibility from personal injury or property damage sustained by or through the use of this product.

PRE ASSEMBLY CHECK LIST

SPECIFICATIONS

- Drive Motor: 2.5 hp
- Speed Range: 1.0 – 16 kmph
- Running Surface: 510 x 1400 m/m
- Incline Level: 0-15 levels
- Folding Design: Yes

Getting started:

Power the treadmill on by plugging it into an appropriate wall outlet, then turn on the power switch located at the front of the treadmill below the motor hood. Ensure that the safety key is installed, as the treadmill will not power on without it.

When the power is turned on, a message will scroll across the dot matrix showing the current

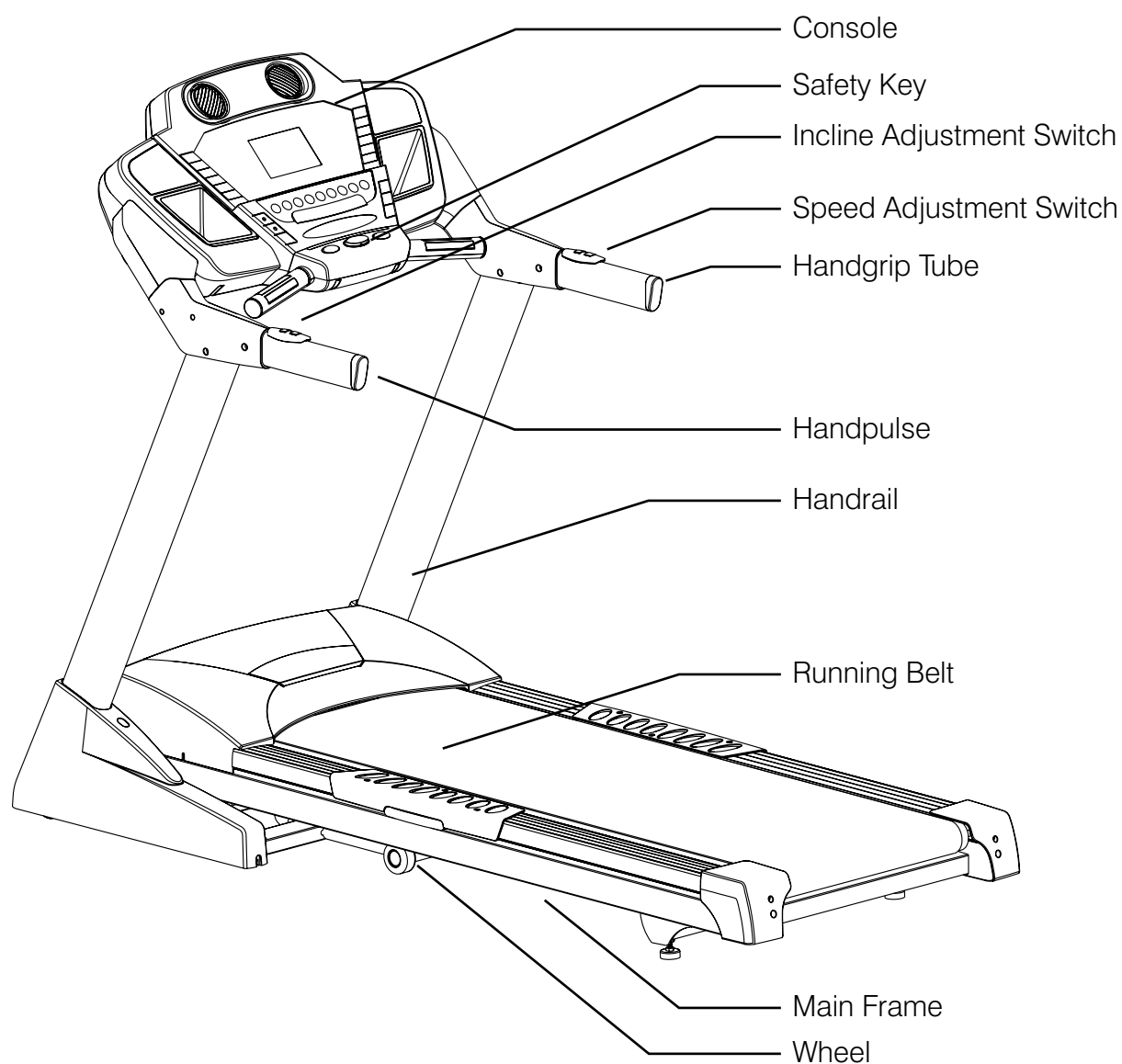

PARTS LIST

No.	Description	Q'ty	No.	Description	Q'ty
10155-01	Main Frame	1	10155-32	Top Frame Cover	1
10155-02	Frame Base	1	10155-34	Motor	1
10155-03	Incline Bracket	1	10155-35	Incline Motor	1
10155-04	Right Handrail	1	10155-36	Controller (external connection transformer)	1
10155-05	Left Handrail	1	10155-37	Speed Cable (Upper 800mm)	1
10155-06	Console Support	1	10155-38	Incline Cable (Upper 800mm)	1
10155-07	Deck Cross Brace	1	10155-39	Handpulse Assembly	2
10155-08	Outer Slide	1	10155-39-2	Handpulse Wire, Coiled (650mm)	1
10155-09	Inner Slide	1	10155-39-3	Handpulse Assembly Top	2
10155-10	Link	1	10155-39-4	Handpulse Assembly Bottom	2
10155-11	Link Shaft	1	10155-39-5	Handpulse End Cap	2
10155-12	Shaft Bushing	2	10155-40	1000 mIm Sensor W/Cable	1
10155-13	Fastening Bracket	2	10155-41	Breaker	1
10155-14	Clevis Pin	1	10155-42	Power Socket	1
10155-15	Fastening Bushing	1	10155-43	On/Off Switch	1
10155-16	Dual Rota-Spring	1	10155-44	Power Cord	1
10155-17	Release Lever	1	10155-45	Connecting Wires (Black 100mm)	2
10155-18	ChenChin Rota-Spring	1	10155-46	Connecting Wires (White 150mm)	1
10155-19	Cylinder	1	10155-47	Connecting Wires (Black 100mm)	1
10155-20	Drive Belt	1	10155-48	Computer Cable (Upper 800mm)	1
10155-21	Front Roller W/Pulley	1	10155-49	Computer Cable (Lower 1150mm)	1
10155-22	Rear Roller	1	10155-50	Computer Cable (Middle 1100mm)	1
10155-23	Running Deck	1	10155-51	Sensor Rack	1
10155-24	Running Belt	1	10155-52	Console Assembly	1
10155-25	Handle Bar Axle Inner Cover	2	10155-52-1	Top Console Cover	1
10155-27	Steel Rope Drawspring	1	10155-52-2	Bottom Console Cover	1
10155-28	Wire Clamp	1	10155-52-5	Beverage Holder (L)	1
10155-29	Wire Tie Mount	6	10155-52-6	Beverage Holder (R)	1
10155-30	Bottom Frame Cover	1	10155-52-14	Front Console Cover (Top)	1
10155-31	Steel Rope	1	10155-52-15	Front Console Cover (Bottom)	1





PARTS LIST

No.	Description	Q'ty	No.	Description	Q'ty
10155-52-16	Safety Switch Module w/Cable (300mm)	1	10155-69	Rear Adjustment Base (R)	1
10155-52-17	Fan	1	10155-70	Motor Cover Anchor	5
10155-52-18	Deflector Fan Grill	2	10155-71	Nylon Washer (ø10 x ø24 x 3T)	2
10155-52-19	Fan Grill Anchor	4	10155-72	Nylon Washer (B ø50 x ø13 x 3T)	4
10155-52-20	Speaker w/Cable (700mm)	1	10155-73	Foot Pad	2
10155-52-21	Speaker w/Cable (250mm)	1	10155-74	Motor Bracket	1
10155-52-22	Amplifier	1	10155-75	Ellipse Safety Key (800mm)	1
10155-52-25	Receiver, HR Assembly	1	10155-76	Belt Guide	2
10155-52-27	Speaker Iron Net (L)	1	10155-77	Wheel Sleeve	2
10155-52-28	Speaker Iron Net (R)	1	10155-78	Magnet	2
10155-52-30	Badge	1	10155-80	Carriage Bolt (1/2" x 1-1/4")	2
10155-52-31	Power Cord of Amplifier (40cm)	1	10155-81	Hex Head Bolt (1/2" x 1")	2
10155-52-32	Sheet Metal Screw (3 x 10mm)	2	10155-82	Socket Head Cap Bolt (Alloy Steel 3/8" x 4-1/2")	1
10155-52-33	Console Ground Wire (400mm)	1	10155-83	Hex Head Bolt (3/8" x 3-3/4")	1
10155-53	Top Motor Cover	1	10155-84	Hex Head Bolt (3/8" x 1-1/2")	1
10155-54	Speed Adjustment Switch w/Cable (300mm)	1	10155-85	Hex Head Bolt (3/8" x 3/4")	4
10155-55	Incline Adjustment Switch W/Cable (300mm)	1	10155-86	Flat Head Socket Bolt (3/8" x 2")	2
10155-56	Cushion	6	10155-87	Button Head Socket Bolt (5/16" x 1")	2
10155-57	Wheel (A)	2	10155-88	Button Head Socket Bolt (5/16" x 2-3/4")	2
10155-58	Wheel (B)	2	10155-89	Hex Head Bolt (M8 x 60mm)	1
10155-59	Square End Cap (30 x 60mm)	2	10155-90	Socket Head Cap Bolt (M8 x 80mm)	2
10155-60	Foot Rail (300mm)	2	10155-91	Flat Head Countersink Bolt (M8 x 80mm)	2
10155-61	Foot Rail (615mm)	2	10155-92	Flat Head Countersink Bolt (M8 x 25mm)	6
10155-62	Frame Base Cap (L)	1	10155-93	Phillips Head Screw (M3 x 10mm)	1
10155-63	Frame Base Cap (R)	1	10155-94	Phillips Head Screw (M5 x 20mm)	1
10155-64	Left Connecting Cap (Top)	1	10155-95	Hex Head Bolt (M8 x 12mm)	2
10155-65	Left Connecting Cap (Bottom)	1	10155-96	Button Head Socket Bolt (5/16" x 42 mm)	1
10155-66	Right Connecting Cap (Top)	1	10155-97	Nyloc Nut (M5)	1
10155-67	Right Connecting Cap (Bottom)	1	10155-98	Nyloc Nut (1/2")	4
10155-68	Rear Adjustment Base (L)	1	10155-99	Nyloc Nut (3/8")	4

PARTS LIST

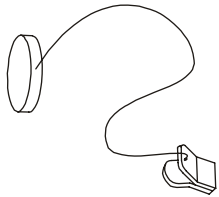
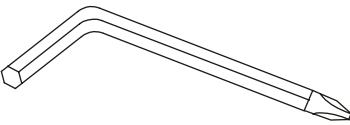
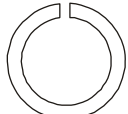
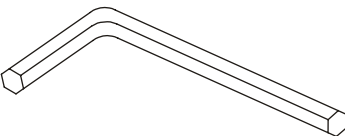
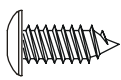
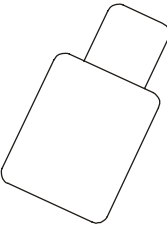
No.	Description	Q'ty	No.	Description	Q'ty
10155-100	Nyloc Nut (5/16")	3	10155-130	Button Head Socket Bolt (5/16" x 1/2")	8
10155-101	Nyloc Nut (M8)	1	10155-131	Combination M5 Allen Wrench & Phillips Head Screw Driver	1
10155-102	Nyloc Nut (3/8")	3	10155-132	Allen Wrench (M6)	1
10155-103	Nut (M3)	1	10155-133	Controller Back Plate	1
10155-104	Flat Washer (ø35 x ø5/16" x 1.5T)	2	10155-134	Lubricant	1
10155-105	Flat Washer (ø25 x ø10 x 1.5T)	4	10155-136	Ellipse End Cap	2
10155-161	Phillips Head Screw (M5 x 10mm)	4	10155-137	Sheet Metal Screw (3.5 x 32mm)	8
10155-162	Split Washer (M5 x 1.5T)	4	10155-139	Button Head Socket Bolt (3/8" x 1-3/4")	4
10155-106	Flat Washer (ø19 x ø10 x 1.5T)	4	10155-140	Phillips Head Screw (M5 x 10mm)	8
10155-107	Flat Washer (ø5 x ø10 x 1.0T)	2	10155-141	Left Handgrip Side Cap (L)	1
10155-108	Flat Washer (ø5/16" x ø18 x 1.5T)	1	10155-142	Left Handgrip Side Cap (R)	1
10155-109	Flat Washer (ø5 x ø12 x 1.0T)	1	10155-143	Right Handgrip Side Cap (L)	1
10155-110	Flat Washer (ø1/4" x 19 x 1.5T)	2	10155-144	Right Handgrip Side Cap (R)	1
10155-111	Concave Washer (ø6.5 x ø25 x 1.5T)	8	10155-145	Cushion Spacer (L)	1
10155-112	Split Washer (M8)	2	10155-146	Cushion Spacer (R)	1
10155-113	Split Washer (ø10)	8	10155-147	Top Motor Cover Plate	1
10155-114	Split Washer (M3)	1	10155-148	Pedal Cover (Top)	2
10155-115	Star Washer (M5)	4	10155-149	Pedal Cover (Bottom)	16
10155-116	Sheet Metal Screw (4 x 12mm)	20	10155-150	Chest Strap	1
10155-117	Tapping Screw (5 x 16mm)	46	10155-151	Chest Strap (1000mm)	1
10155-118	Tapping Screw (5 x 19mm)	1	10155-152	Bolt Cap (13mm)	2
10155-119	Sheet Metal Screw (3.5 x 12mm)	35	10155-153	Audio Cable (400mm)	1
10155-120	Tapping Screw (5 x 16mm)	13	10155-154	Plastic Washer	4
10155-121	Flat Washer (ø13 x ø32 x 2.5T)	2	10155-156	Drink Bottle	1
10155-124	Tapping Screw (3 x 12mm)	4	10155-157	Sheet Metal Screw (3.5 x 18mm)	6
10155-125	Sheet Metal Screw (4 x 50mm)	2	10155-158	Filter	1
10155-126	Tapping Screw (3.5 x 16mm)	6	10155-159	Choke	1
10155-127	Sheet Metal Screw (3 x 10mm)	2	10155-160	Connecting Cable of Motor (400mm)	1
10155-128	Speed Nut Clip (M5)	6	10155-161	Phillips Head Screw (M5 x 10mm)	4
10155-129	Sheet Metal Screw (3 x 8mm)	6	10155-162	Split Washer (M5 x 1.5T)	4

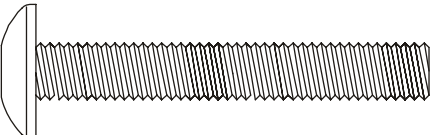
HARDWARE PARTS LIST

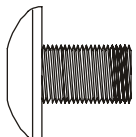
No.	Description	Q'ty	No.	Description	Q'ty
10155-75	 Safety Key	1pc	10155-131	 Combination M5 Allen Wrench & Phillips Head Screw Driver	1pc
10155-113	 Split Washer (ø10)	4pcs	10155-132	 Allen Wrench (M6)	1pc
10155-119	 Sheet Metal Screw (3.5 x 12mm)	4pcs	10155-134	 Lubricant	1pc
10155-120	 Tapping Screw (5 x 16mm)	6pcs	10155-139	 Button Head Socket Bolt (3/8" x 1-3/4")	4pcs
10155-128	 Speed Nut Clip (M5)	6pcs	10155-140	 Phillips Head Screw (M5 x 10 mm)	8pcs
10155-130	 Button Head Socket Bolt (5/16" x 1/2")	8pcs			

Above described parts are all the parts you need to assemble this machine. Before you start to assemble, please check the hardware packing to make sure they are included.

EXPLODED DIAGRAM

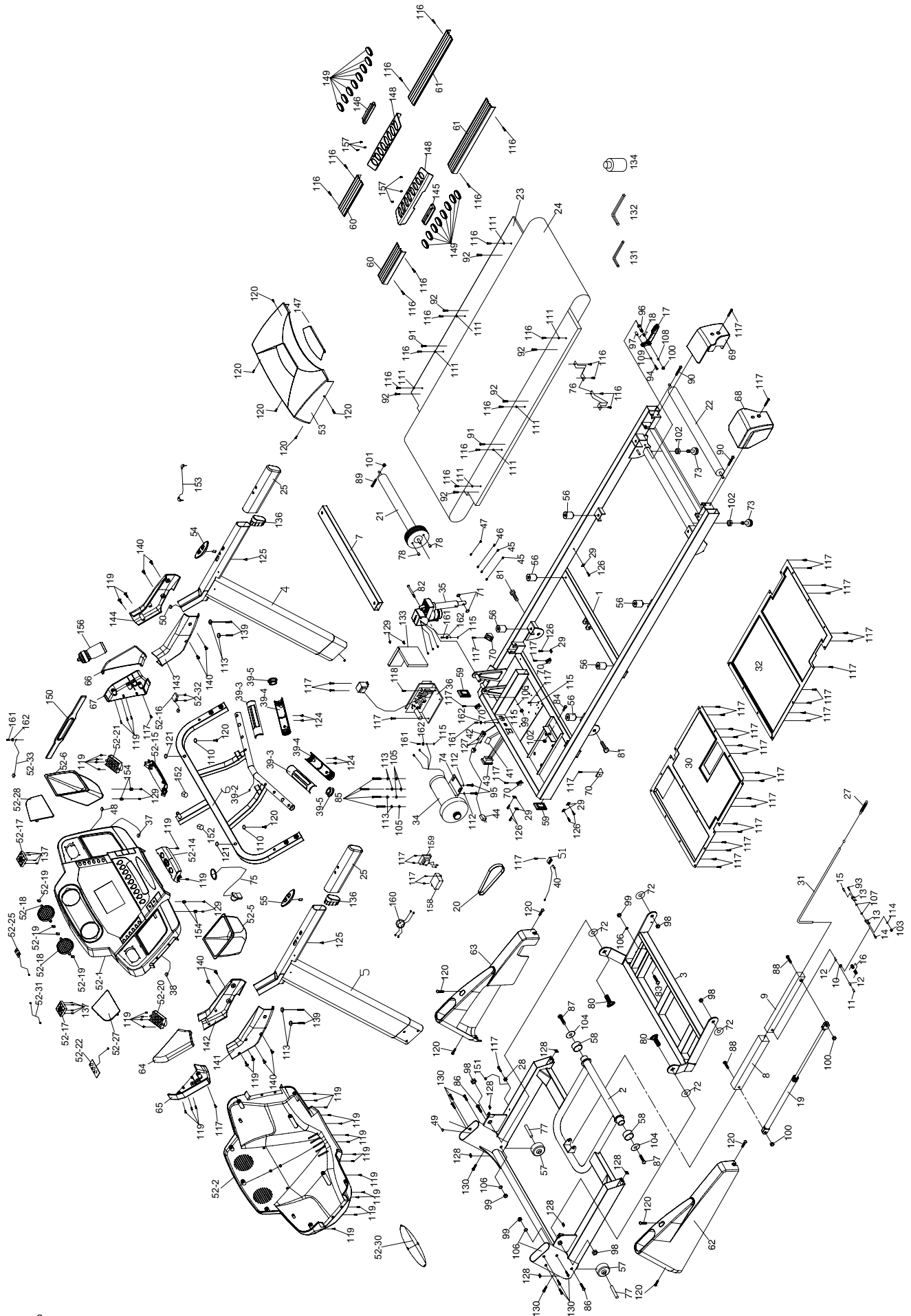

ASSEMBLY INSTRUCTION

STEP 1

Remove the treadmill from the carton and lay it on smooth, level ground.

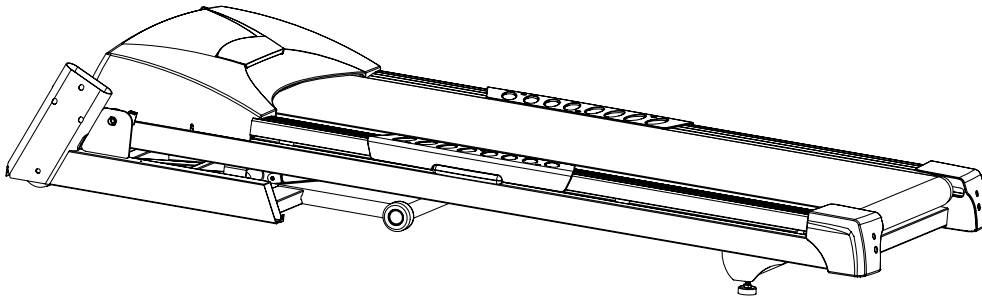

STEP 2

- Install the 6pcs of Speed Nut Clips (128) on the Frame Base left and right side.
- Install the Frame Base Cap (62 & 63) through the Upright tubes (4 & 5), and connect the Computer Cable (Lower 49) to the Computer Cable (Middle 50).

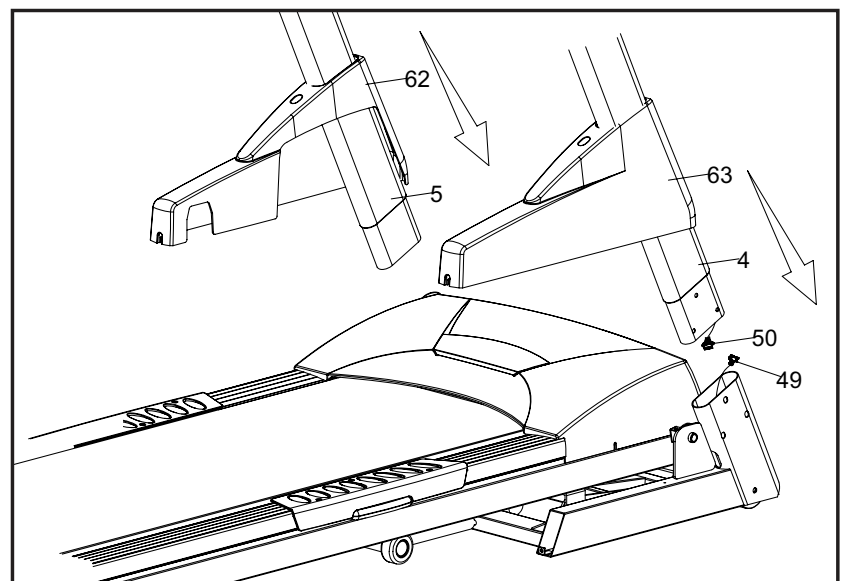
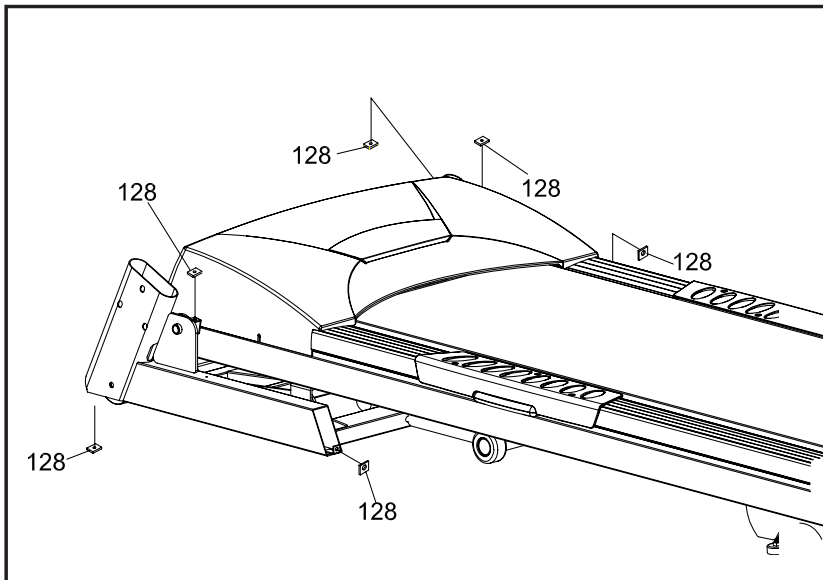

ASSEMBLY INSTRUCTION

STEP 3

- Install the upright tubes (4 & 5) into the Frame Base (2) with the 8pcs of 5/16"x1/2" Button Head Socket Bolts (130) using the Combination M5 Allen Wrench & Phillips Head Screw Driver.

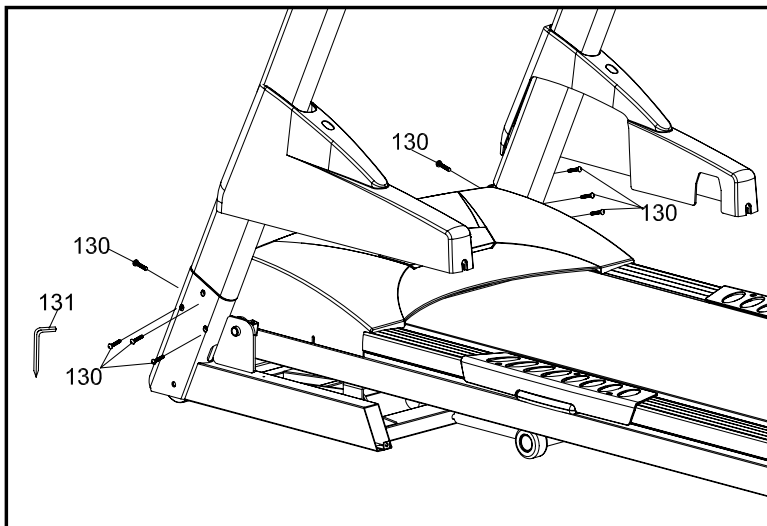

STEP 4

- Install the Frame Base Caps (61 & 62) on the Frame Base (2) with the 6pcs of 5x16mm Tapping Screws (120) using the Combination M5 Allen Wrench & Phillips Head Screw Driver (131).

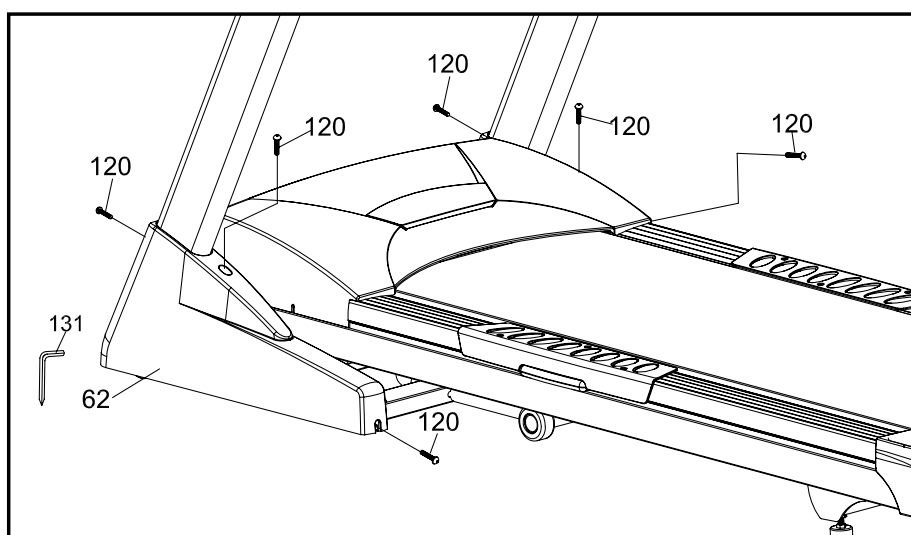

ASSEMBLY INSTRUCTION

STEP 5

- Connect the Speed Adjustment Switch Cable (#54) to the Speed Cable, Upper (#37).
- Connect the Incline Adjustment Switch Cable (#55) to the Incline Cable, Upper (#38).
- Connect the Computer Cable, Middle (#50) and Computer Cable, Upper (#48).

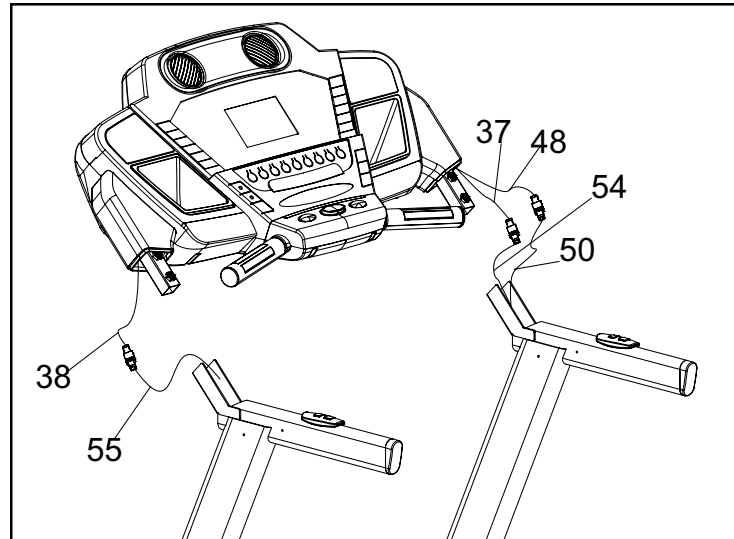

STEP 6

- Install the Console Assembly (#52) into the upright tubes (#4 & #5) with the 4pcs of 3/8"x1-3/4" Button Head Socket Bolts (#139) and 4pcs of 10mm Split Washers (#113) using the M6 Allen Wrench (#132).

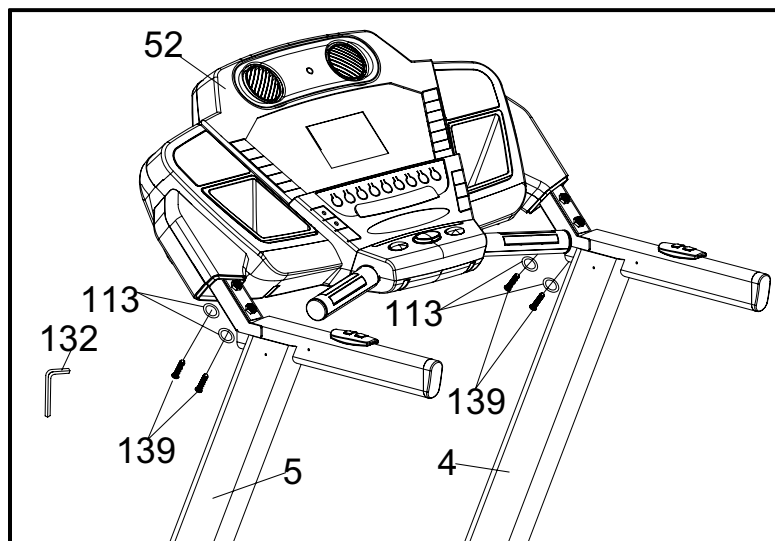

ASSEMBLY INSTRUCTION

STEP 7

- Install the Left Handgrip Side Cap and Right Handgrip Side Cap to cover the top of the upright tubes (#4 & #5) and Console Assembly Support tubes, with the 8pcs of M5x10mm Phillips Head Screws (#140) and 4pcs of 3.5x12mm Sheet Metal Screws (#119) using the Combination M5 Allen Wrench & Phillips Head Screw Driver (#131).

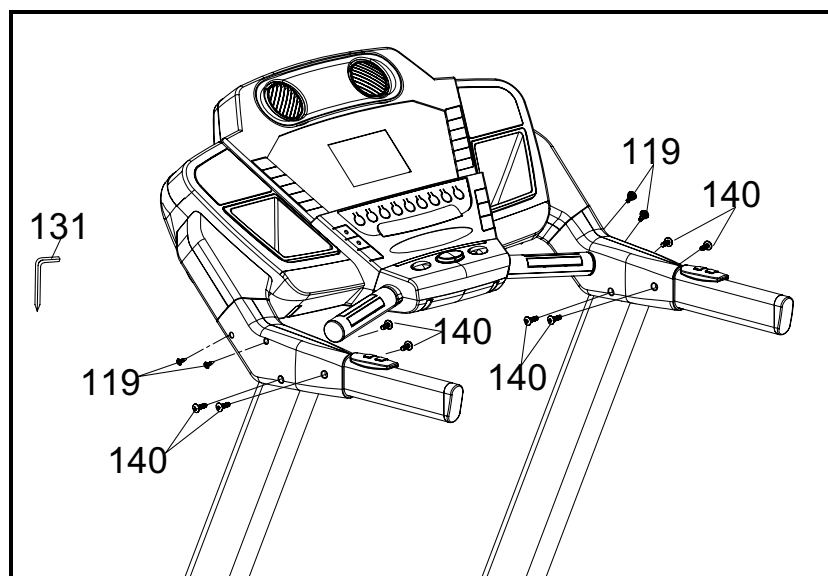

Note: Please tighten all screws after all components have been assembled.

COMPUTER OPERATION INSTRUCTIONS



When the power is turned on, a message will scroll across the dot matrix showing the current software version. Then the Time and Distance windows will display Odometer readings for a short time, Time window will show how many hours the treadmill has been in use and the Distance window will show how many miles (or Kilometers if the treadmill is set to metric readings) the treadmill has gone. The treadmill will then enter idle mode, which is the startingpoint for operation. Getting started:

Power the treadmill on by plugging it into an appropriate wall outlet, then turn on the power switch located at the front of the treadmill below the motor hood. Ensure that the safety key is installed, as the treadmill will not power on without it.

COMPUTER OPERATION INSTRUCTIONS

Quick-Start Operation:

STEP 1: Insert the Safety key to light up the display (if not already on).

STEP 2: Press the Start key to begin belt movement then adjust to the desired speed using the Fast / Slow keys (console or handgrip). You may also use the rapid speed keys 2 through 12 to adjust the speed.

STEP 3: To slow tread-belt press and hold the Slow key (console or handgrip) to the desired speed. You may also press the rapid speed adjust keys, 2 through 12.

STEP 4: To stop the tread-belt press Stop key or pull away Safety key.

Pause/Stop/Reset Feature:

STEP 1: When the treadmill is running the pause feature may be utilized by pressing the red Stop key once. This will slowly decelerate the tread-belt to a stop. The incline will go to zero percent. The Time, Distance and Calorie readings will hold while the unit is in the pause mode. After 5 minutes the display will reset and return to the start up screen.

STEP 2: To resume your exercise, when in Pause mode, press the Start key. The speed and incline will return to their previous settings.

- Pause is executed when the Stop button is pressed once. If the Stop key is pressed a second time, the program will end and a workout summary will be displayed. If the Stop button is pressed a third time, the console will return to the idle mode (start up) screen. If the Stop button is held down for more than 3 seconds the console will reset.

Incline Feature:

- Incline may be adjusted anytime after belt movement.
- Press and hold the **Adjust ▲ ▼** keys (console or handgrip) to achieve desired level of effort. You may also choose a more rapid increase / decrease by selecting desired key, 2 through 12, on left hand side of console (incline).
- The display will indicate incline position as adjustments are made.

Dot Matrix Center Display (Program Operation):

Twenty columns of dots (8 high) indicate each segment of a workout. The dots are only to show an approximate level (speed/incline) of effort. They do not necessarily indicate a specific value - only an approximate percent to compare levels of intensity. In operation the Speed / Incline dot matrix window will build a profile "picture" as values are changed during a workout.

When the Speed indicator which is above dot matrix is lit the Dot matrix displays the Speed profile and when the Incline indicator is lit the Dot Matrix displays the Incline profile.

You may change the Dot Matrix profile view which you desired by pressing the SELECT button.

After scrolling through the three profiles which include incline, speed and incline+ speed profile, by pressing the SELECT button, the Dot matrix will automatically scroll through the three displays showing each one for five seconds.

COMPUTER OPERATION INSTRUCTIONS

0.4km (1/4 mile) Track:

The 0.4km (1/4 mile) track will be displayed around the dot matrix window. The flashing dot indicates your progress. Once the 0.4km (1/4 mile) is complete this feature will begin again. The amount of laps are accumulated in the laps window which is below PULSE.

Pulse Grip Feature:

The Pulse (Heart Rate) console window will display your current heart rate in beats per minute during the workout. You must use both stainless steel sensors on the front cross bar to display your pulse or the wireless chest strap. Pulse value displays anytime the upper display is receiving a Pulse signal.

Calorie Display:

Displays the cumulative calories burned at any given time during your workout.

Note: This is only a rough guide used for comparison of different exercise sessions, which cannot be used for medical purposes.

Optional: *There is an Audio Input Jack on the front of the console and built-in speakers. You may plug any low-level audio source signal into this port. Audio sources include MP3, Ipod, portable radio, CD player or even a TV or computer audio signal. There is an audio patch cable included to and also a headphone jack for private listening.*

To Turn Treadmill Off (Blank out Display):

Two methods accomplish this: Use either one.

- (1) Display will automatically turn off (blank out) after 10 minutes (no key operations) in Pause / Stop mode.
- (2) Remove safety key.

Programmable Features

Factory preset programs, 2 user defined programs, one Manual program (P0) and P1-P5 programs. Each preset program has a maximum speed level that is displayed when a desired workout is chosen. The maximum speed that the particular program will achieve will be displayed in the Speed window. Also included are two user programs (User 1 and User 2) for custom workouts.

COMPUTER OPERATION INSTRUCTIONS

To Select a Program:

- STEP 1:** Press the **PROGRAM ▲ ▼** key to select desired program which include Manual (P0) and P1-P5. Press enter to select the program. The display will prompt you through the programming or you can just press Start to begin the program with default values.
- STEP 2:** If enter was pressed, the Time window will display with the default value of 20 minutes. You may use any of the up/down, fast/slow keys to adjust the time. After adjusting, or to accept the default value, press enter. (Note: You may press start at any time during the programming to start the program.)
- STEP 3:** The Calorie window will now be displaying a value, which is your Body Weight. Entering the correct body weight will affect the calorie count. Use the Up/Down keys, Fast/Slow to adjust, then press enter.
A note about the Calorie display: No exercise machine can give you an exact calorie count because there are too many factors which determine exact calorie burn for a particular person. Even if someone is the exact same body weight, age and height, their calorie burn may be very different than yours. The Calorie display is to be used as a reference only to monitor improvement from workout to workout.
- STEP 4:** The Calorie window will display the preset top speed of the selected program. Use the Up/Down, Fast/Slow keys to adjust, and then press enter. Each program has various speed changes through out, this allows you to limit the highest speed the program can reach.

User Programs:

- STEP 1:** Select User 1 or User 2 via the PROGRAM key then press Enter. Note that the dot matrix display portion will have a single row of dots at the bottom (Unless there is a previously stored program).
- STEP 2:** Note the Time window is flashing. Use the **Adjust ▲ ▼** keys to adjust up from 10 minutes (if desired). Press ENTER key. This is a must to continue even if time is not adjusted.
- STEP 3:** The Calorie window will now be blinking a bodyweight value. Enter your bodyweight and press Enter.
- STEP 4:** The first column (segment) will now be blinking. Using the Fast / Slow or rapid keys, adjust the speed level to your desired effort for the first segment then press enter. The second column will now be blinking. Repeat the above process until all segments have been programmed. The first column will be blinking again. This is for the incline programming. Repeat the above process to program all segments for incline.
- STEP 5:** Press the Start button to begin the workout and also save the program to memory.

LUBE INDICATOR:

Every 180 hours or 1000km of use apply one half bottle of lubricant between running belt and running board.

COMPUTER OPERATION INSTRUCTIONS

ERROR MESSAGE:

1. LS: Treadmill doesn't receive the speed signal for 8 seconds.
2. E1: Memory of console malfunction or CPU accessing problem.
3. E2: Incline position error.

Program

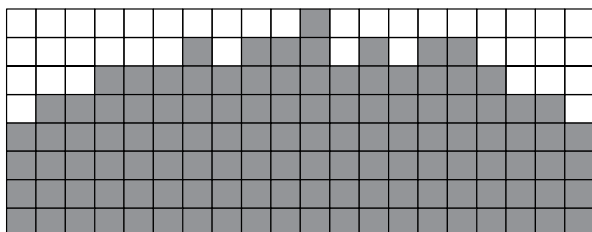

P1 SPEED PROGRAM

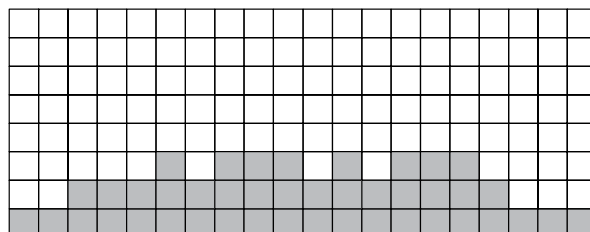

P1 INCLINE PROGRAM

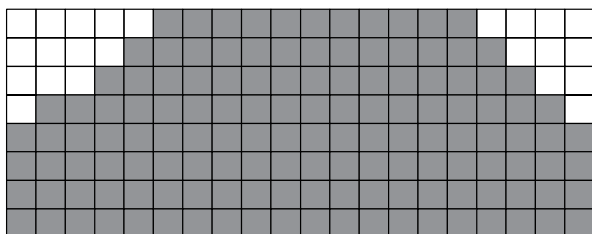

P2 SPEED PROGRAM

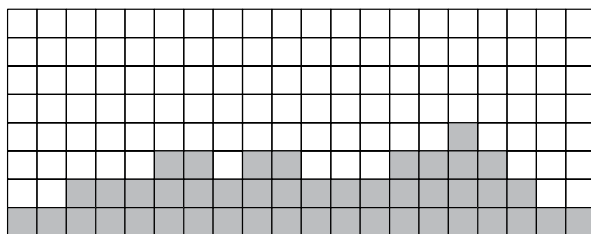

P2 INCLINE PROGRAM

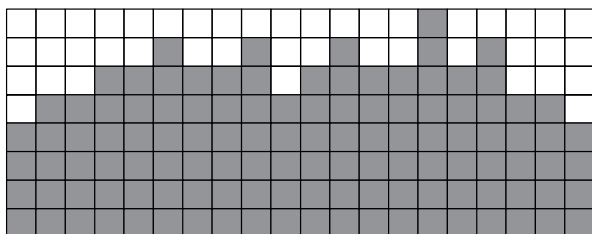

P3 SPEED PROGRAM

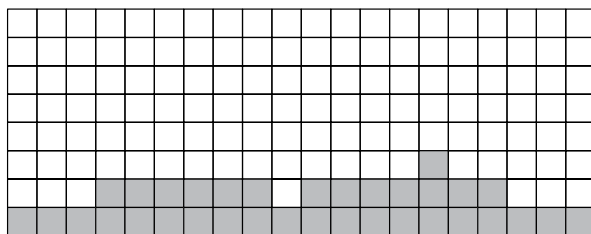

P3 INCLINE PROGRAM

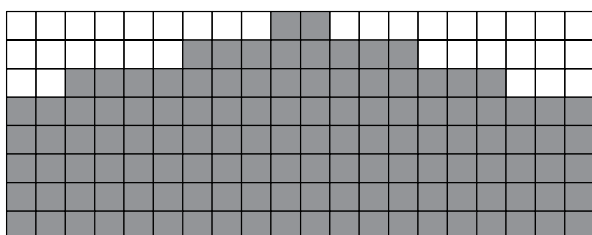

P4 SPEED PROGRAM

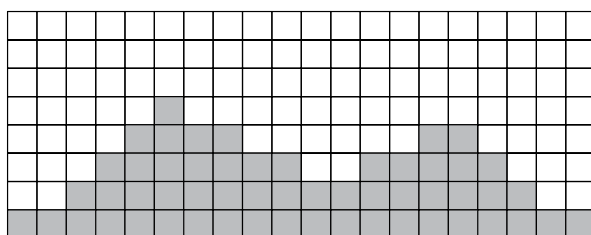

P4 INCLINE PROGRAM

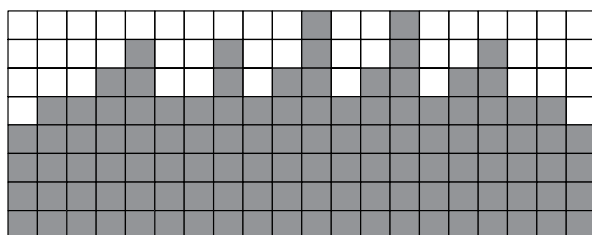

P5 SPEED PROGRAM

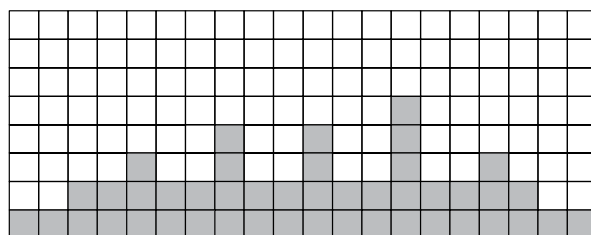

P5 INCLINE PROGRAM

UNFOLDING/FOLDING AND TRANSPORT



Do not attempt to move the unit unless it is in the folded and locked position. Be sure the power cord is secured to avoid possible damage. Use both handrails to maneuver the unit to the desired position.

Unfolding The Treadmill:

Apply slight forward pressure* on the treadmill running deck with one hand. Pull down on the unlocking lever and slowly lower the running deck to the floor. The deck will lower unassisted when it reaches about waist high. (As shown Figure 1.)

*At the rear roller area to relieve pressure on the locking system.

Folding The Treadmill:

Make certain the treadmill is at minimum incline. Lift the treadmill running deck until it is secured by the locking telescoping tube assembly in center back of base.

(As shown Figure 2&3.)

Transport

The treadmill is equipped with four transport wheels which are engaged when the treadmill is folded. After folding simply roll the treadmill away. (As shown Figure 4.)

BELT TRACKING ADJUSTMENT



If during use you notice that walking belt either shifts to the right or the left of center, first remove "Safety Key" and unplug equipment from AC power source. Using M6 Allen wrench provided, turn left rear roller adjustment as indicated below clockwise no more the 1/4" of a turn. Remove M6 Allen wrench, insert "Safety Key" and insert AC power cord into AC outlet. Turn on your treadmill and observe after running a few minutes to see if problem has been corrected. This may take several adjustments, so repeat the above procedure.

TREADMILL LUBRICATION



Your treadmill should require little maintenance other than periodically applying lubricant. Lubricating under the running belt will ensure superior performance and extend its life expectancy.

HOW TO CHECK THE RUNNING BELT FOR PROPER LUBRICATION?

Lift one side of the running belt and feel the top surface of the deck.

If the surface is slick to the touch, then no further lubrication is required.

If the surface is dry to the touch, apply one packet of lubricant or half of the bottle of lubricant.

HOW TO APPLY LUBRICANT?

1. Lift one side of treadbelt.
2. Pour one half of the lubricant bottle under the center of the treadbelt on the top surface of the deck.
3. Walk on the treadmill at a slow speed for 3 to 5 minutes to evenly distribute lubricant.

NOTE: DO NOT over lubricate treadmill. Any excess lubricant that comes out should be wiped off.

IMPORTANT: NEVER USE MORE THAN HALF THE BOTTLE OF LUBRICANT PER APPLICATION LUBRICATION SCHEDULE.

1. It is best to lubricate your treadmill before you use it for the first time.
2. If you do not lubricate your treadmill before you use it for the first time, you should lubricate it after the first 25 hours of use (2-3 months).
3. Every 180 hours or 1000km of use, apply half a bottle of lubricant.

EXERCISE INSTRUCTIONS

Using your TREADMILL will provide you with several benefits. It will improve your physical fitness, tone muscle and in conjunction with a calorie controlled diet, help you lose weight.

1. The Warm Up Phase

This stage helps get the blood flowing around the body and the muscles working properly. It will also reduce the risk of cramp and muscle injury. It is advisable to do a few stretching exercises as shown below. Each stretch should be held for approximately 30 seconds, do not force or jerk your muscles into a stretch - if it hurts, STOP.



2. The Exercise Phase

This is the stage where you put the effort in. After regular use, the muscles in your legs will become more flexible. Work to your own pace but try to maintain a steady tempo throughout. The rate of work should be sufficient to raise your heart beat into the target zone shown on the graph below.

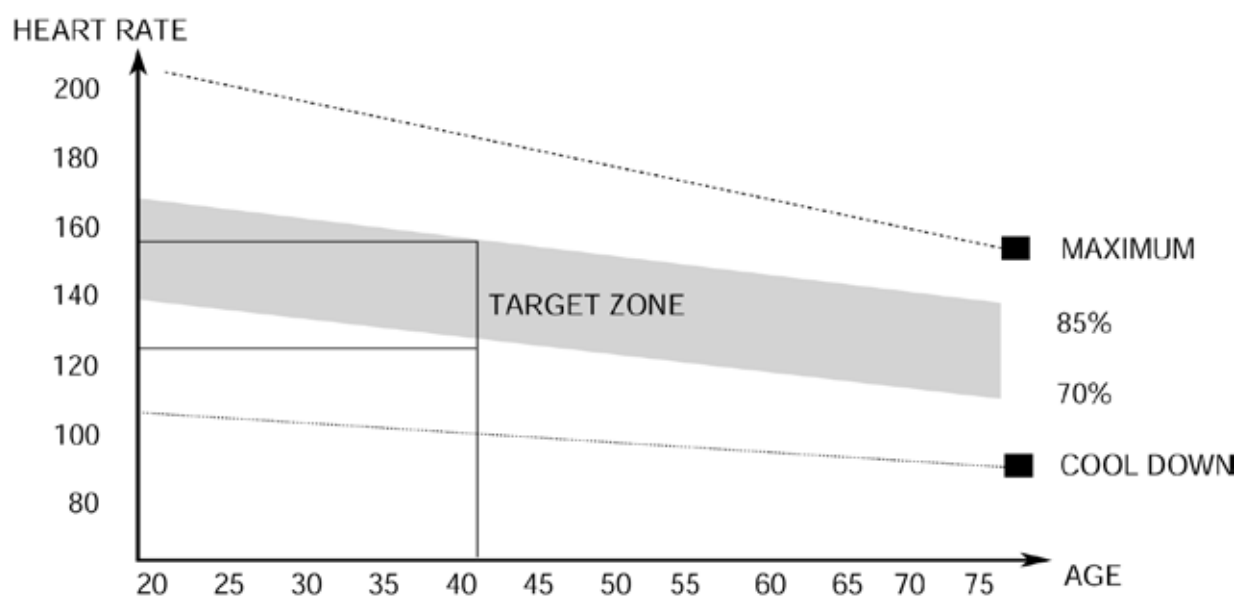

This stage should last for a minimum of 12 minutes though most people start at about 15-20 minutes.

EXERCISE INSTRUCTIONS

3. The Cool Down Phase

This stage is to let your Cardio-vascular System and muscles wind down. This is a repeat of the warm up exercise, however reduce your tempo and continue for approximately 5 minutes. The stretching exercises should now be repeated, again remembering not to force or jerk your muscles into the stretch.

As you get fitter you may need to train longer and harder. It is advisable to train at least three times a week, and if possible space your workouts evenly throughout the week.

MUSCLE TONING

To tone muscle while on your TREADMILL you will need to have the resistance set quite high. This will put more strain on your leg muscles and may mean you cannot train for as long as you would like. If you are also trying to improve your fitness you need to alter your training program. You should train as normal during the warm up and cool down phases, but towards the end of the exercise phase you should increase resistance making your legs work harder. You will have to reduce your speed to keep your heart rate in the target zone.

WEIGHT LOSS

The important factor here is the amount of effort you put in. The harder and longer you work the more calories you will burn. Effectively, this is the same as if you were training to improve your fitness, the difference is the goal.

SPIRIT 1 YEAR LIMITED WARRANTY

Masstores (Pty) Ltd (“the Supplier”) hereby provides a limited warranty to the original purchaser of this product (“the Consumer”) that this product will be free of manufacturing defects in materials and workmanship which under normal, personal, family or household use (commercial use expressly excluded) manifest themselves within the following stipulated periods from the date of purchase:

Exclusions

The warranty does not include and will not be construed to cover products damaged as a result of disaster, misuse, commercial use, use not in accordance with the written instructions included with the product, abuse, and/or any non-authorized modification of the product. It also does not cover replacement of the light bulbs and other expendables. All demo models carry a 3 month warranty.

Waiver

The warranty provided herein and the obligations of the Supplier are in lieu of, and the Customer waives, all other warranties, guarantees, conditions or liabilities, express or implied, arising by law or otherwise, including without limitation, any obligation of the Supplier in respect of any injury, loss or damage (direct, indirect or consequential) arising out of the use of, or inability to use, this product and whether or not occasioned by the Supplier’s negligence or any act of omission on its part.

CLAIMS UNDER 1 YEAR LIMITED WARRANTY

- **Within 7 days of purchase:**

The faulty product will be exchanged (provided that the product is in its original packaging with all accessories).

- **After 7 days but within 3 months of purchase:**

The Supplier may in its sole discretion either replace or repair the product.

- **After 3 months but within 1 year of purchase:**

The Supplier may in its sole discretion either replace or repair the product. The following shall not be covered:

TREADMILLS : Running Decks, Running Belts, and Rubber Arm covers

EXERCISE BIKES / SPINNERS : Pedals, Cranks, Seats and Rubber Arm covers

CROSS TRAINERS / ELLIPTICALS / STEPPERS : Foot Rests, Cranks, Shocks, and Rubber / Foam Arm Covers

HOME GYMS : Pulleys, Cables, Seats and Padding

TRAMPOLINES : Springs, Mats and Covers

ROWERS : Rowing Strap / Rope /Arms, Pulling Handle, Grip, Moveable Seat

VIBRATION TRAINERS : Platform / Rubber Arm Cover / Resistance Bands

Parts not mentioned in the above, are covered under warranty within the 1st year of purchase.

SPIRIT REPAIRS PROCEDURE

1. Procedure for repairs

Should you experience any faults or breakdowns on your Spirit equipment, please adhere to the following procedure to have the fault rectified speedily and professionally.

- Do not return the product to the store.
- Call the Service Centre to log the faulty product (under warranty or out of warranty).
- The operator or technical advisor will try to identify the fault and will book a service.
- The service team will take the faulty product back to the service centre.
- Once the item has been repaired it will be returned to the Consumer's home on an agreed date and time.

Note: Should you live in an outlying area, it may be necessary to return the product to the store nearest to you. Our service operator will advise you of your repair procedure.

2. Cost of repairs

2.1. Under warranty

- Any items still under warranty will be repaired free of charge, as long as it complies with the terms and conditions of the warranty (refer to "warranties" section of this manual).
- Any items that need to be repaired that are NOT covered in the warranty will be for the Consumer's expense. A quote for the repair/replacement of these items will be provided to the Consumer for approval prior to repairs being conducted.

2.2. Out of warranty

- Any items that need to be repaired once the warranty has expired will be for the Consumer's expense, including call-out fees. A quote for the repair/replacement of these items will be provided to the Consumer for approval prior to repairs being conducted.

SERVICE CENTRE NUMBER

For immediate help with assembly or for additional product information, please call our service centre:



(DBN) 031 702 5784 (JHB) 011 907 1660
(CT) 021 934 0862 (PE) 041 487 0573

please have your model name ready when you call us.

PROOF OF PURCHASE

Any claim in terms of the warranty must be supported by a proof of purchase or a warranty number. Warranty numbers can be issued through contacting our Service Centre. If such proof is not available, then notwithstanding anything to the contrary herein, the service agent's prevailing charges for services / repairs including call-out and / or spares will be payable by the Consumer upon collection or delivery of the repaired product.

The Consumer does not need to return the product to the store.

The Consumer shall phone the Service Centre and the Supplier's authorized agent will collect and repair the item at their premises.

During the warranty period the product may only be serviced and/or repaired by the Supplier's duly authorized agent(s).



ATTACH RECEIPT

CLIENT DETAILS:

Name:
E-mail: Cell:
Tel (h): Tel(w):
Address:

PRODUCT DETAILS:

Date of Purchase Serial number
Till slip number:
Description of product:
Branch purchased at:

Masstores (pty) Ltd
16 Peltier Drive, Sunninghill
Sandton, Johannesburg, South Africa

